

LiteBlue LED produces white light by using Gallium Nitride based die of 465 - 470 nanometers wavelength and then excited through a phosphor coating of special formula. The generated blue light is most sensitive in suppressing Melatonin secretion and thus highly efficient to regulate the Circadian Rhythm, when compared with other color light. Blue light can be classified into two categories,

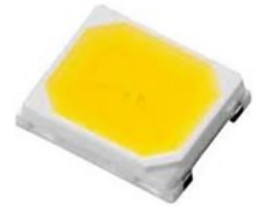

Blue-violet light (415 - 455 nanometers)

Blue-turquoise light (456 - 490 nanometers)

LiteBlue LED emits about 90% of blue-turquoise light within the blue light content, while standard LED of blue pump of 450 nanometers emits about 50% of blue-turquoise light. At the same time, **LiteBlue** LED emits several times less blue-violet light than standard LED.

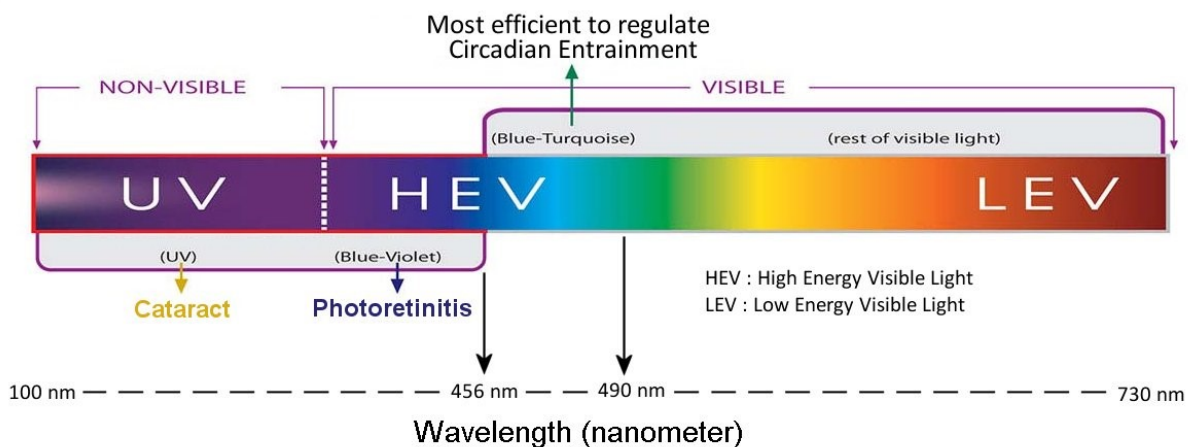

LiteBlue LED offers the following three benefits, as compared with standard LED,

- More efficient to regulate the circadian entrainment during daytime. It also helps cognitive function, elevates moods and synchronizes body-clock.
- Bridging the cyan gap at around 480 nanometer makes the light to be perceived more aesthetically pleasant .
- Less sensitive to Retinal Blue-Light Hazard stated in IEC/EN 62471 (Photobiological safety of lamps and lamp systems) , which is related to the Photoreinitis (i.e. damage to the retina caused by high energy incident light). Also, numerous studies show that blue-turquoise light may be less damaging than blue-violet light, which can bring on Age-related Macular Degeneration and digital eye strain.

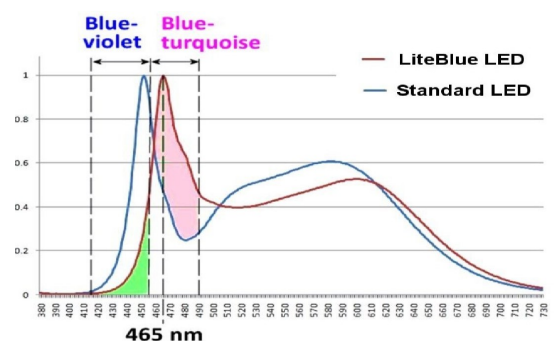

Product specification

Model	EL series
Part number	LB2835-30-465
Ordering number	EL-BLH283580BAN30
LED die material	GaN (Gallium Nitride)
LED die wavelength	465 - 470 nanometers
Package Size	3.50 × 2.80 × 0.7 mm
Viewing angle	120 degree
Color temperature	3000K CCT
Melanopic ratio (@WELL v2)	0.647 (typ.)
Luminous Efficiency	130 lumen/Watt (typ.) at $I_F = 60\text{mA}$
Color Rendering Index	85% (typ.)
RoHS compliant lead-free soldering	compatible

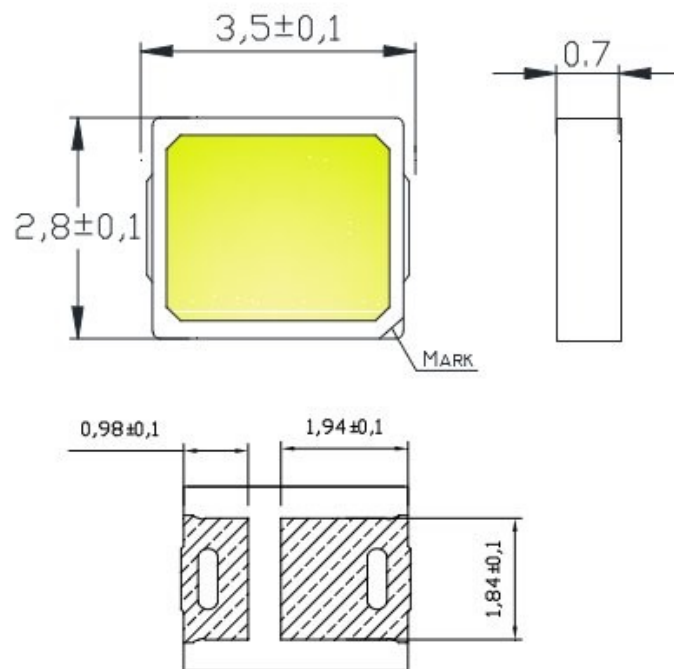

Notes: 1) All dimensions are in millimeters

2) Tolerances are ± 0.05 mm unless otherwise stated

Product Nomenclature

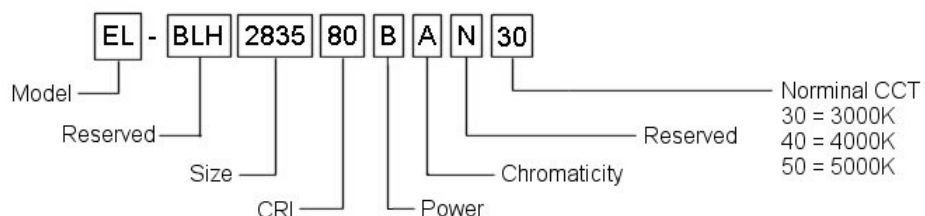

Absolute maximum ratings

	Symbol	Value	Unit
Power dissipation	Pd	0.2	W
Forward current	I _F	60	mA
Reverse voltage	V _R	5	V
Operating temperature range	Topr	-40 to +100	°C
Storage temperature range	Tstg	-40 to +100	°C
Pulse forward current	I _{FG}	80	mA
Electrostatic discharge	ESD	1000 (HBM)	V

Electro-optical characteristics

	Test condition	Symbol	Min.	Typ.	Max.	Unit
Forward voltage	I _F = 60 mA	V _F	2.8	3.0	3.1	V
Luminous flux	I _F = 60 mA	Φ	22	23	24	lm
Viewing angle 50% I _v	I _F = 60 mA	2θ _{1/2}	-	120	-	deg
Reverse current	V _R = 5V	I _R	-	-	0.01	mA
Color temperature	I _F = 60 mA	T _C	2800	3000	3200	K
Chromaticity CIE	I _F = 60 mA	CIE	Refer to CIE 1931 diagram			
CRI (Ra)	I _F = 60 mA	Ra	≥ 80%			

- Notes :
1. Luminous flux measurement tolerance : ±10%
 2. Forward voltage measurement tolerance : ± 0.1V
 3. Color temperature measurement tolerance : ± 0.005
 4. CRI (Ra) measurement tolerance : ± 1%

Typical electro-optical characteristics curves

Relative intensity vs Wavelength

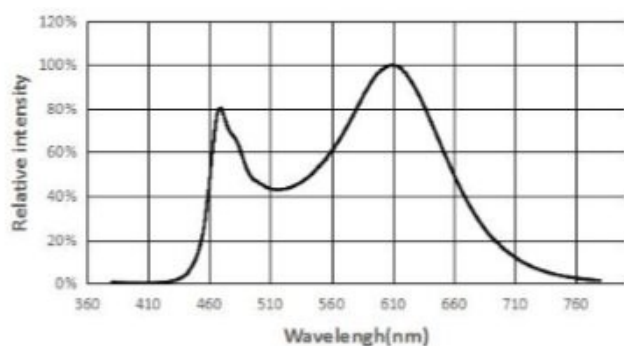

Forward current vs Forward voltage

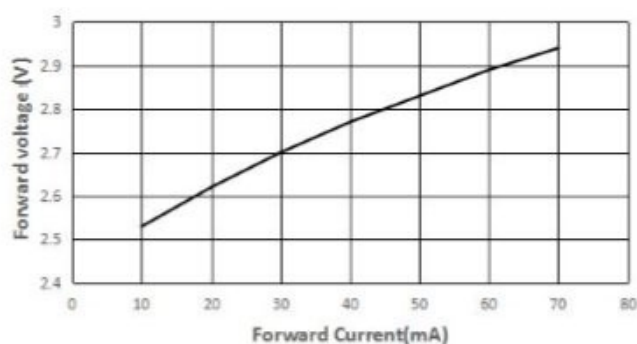

Forward current derating curve
vs Ambient temperature

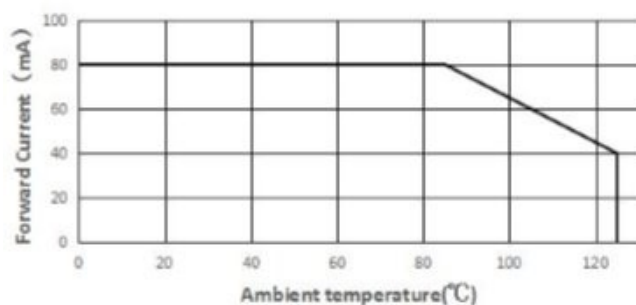

Relative intensity vs Forward current

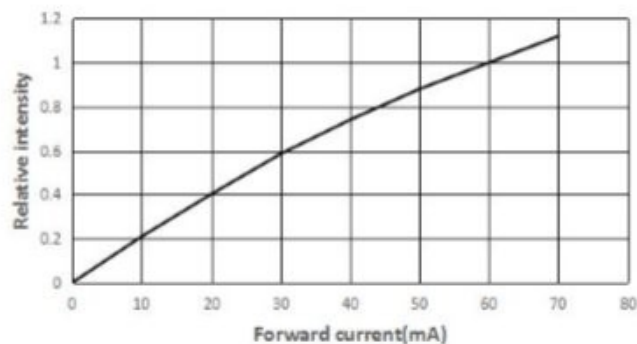

Flux Bin Limit (IF =60mA)

Bin code	Minimum (lumen)	Maximum (lumen)
025	22	24

VF Bin Limit (IF =60mA)

Bin code	Minimum (Volt)	Maximum (Volt)
A3	2.8	2.9
A4	2.9	3.0
A5	3.0	3.1

Chromaticity

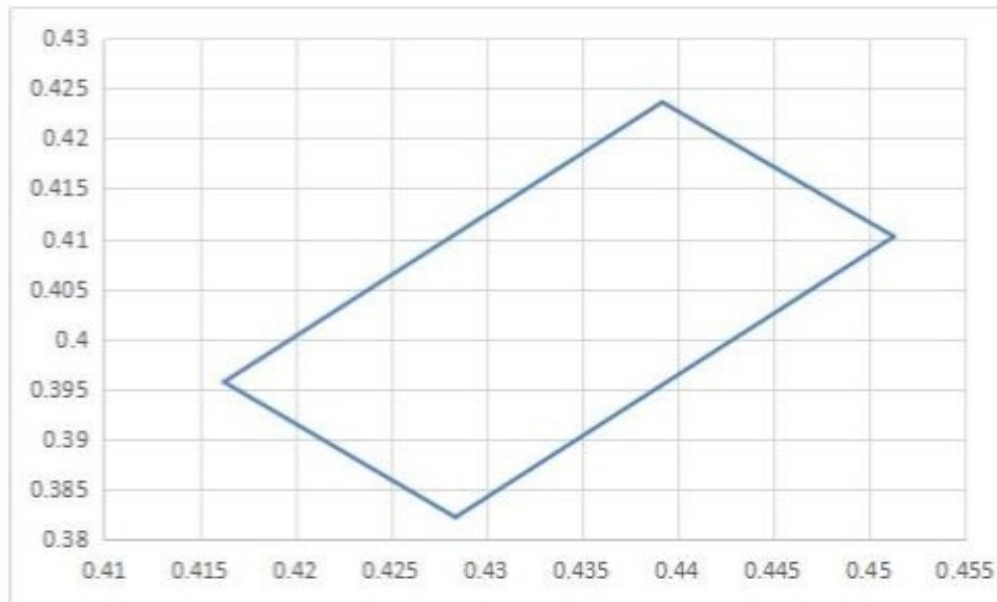

CIE 1931 x,y Chromaticity Diagram

Color Temperature	CCx	CCy
3000K CCT	0.4284	0.3822
	0.4513	0.4102
	0.4392	0.4236
	0.4163	0.3957

Requirements for application and reflow soldering

Pre-heat	120 - 160°C
Pre-heat time	120 seconds max
Peak temperature	245°C max
Condition	Refer to temperature profile

1. After reflow soldering, rapid cooling should be avoided.
2. Use the following conditions shown in the figure below.

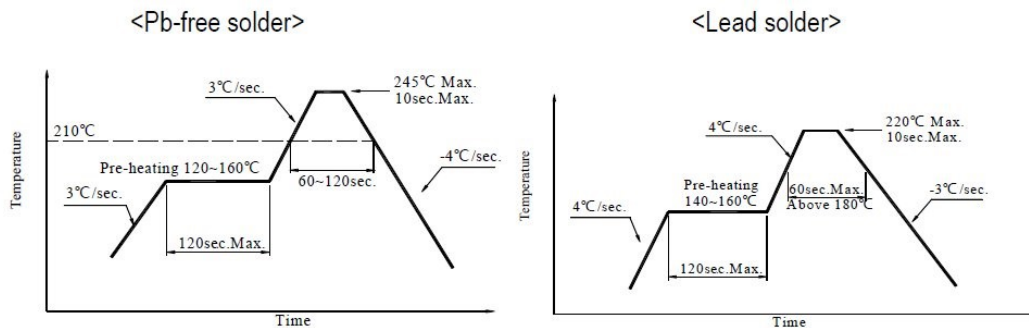

3. Reflow soldering should not be done more than two times.
4. When soldering, do not put stress on the LED during heating.

Handling precautions

Compared with epoxy encapsulation that is hard and brittle, silicone is softer and flexible. Although its characteristic significantly reduces thermal stress, it is more prone to damage by external mechanical force. As a result, special handling and precautions must be observed during assemblies using silicone encapsulated LED product. Failure to comply may lead to damage and premature failure of the LED.

- ◆ Handle the component along the side surface by using forceps or appropriate tools. Please do not touch the Silicone lens surface, because it may damage the internal circuitry.
- ◆ Do not stack the LED on top of each other. Improper handling may scratch the silicone lens or damage the internal circuitry.
- ◆ Not suitable to operate in acidic environment, PH<7.
- ◆ LED operating environment and sulfur element composition cannot be over 25 PPM in the LED mating usage material.
- ◆ When external glue for LEDs application products is used, please make sure that the external glue matches the LEDs packaging glue. Additionally, as most of LED packaging glue is silica gel, and it has strong Oxygen permeability as well as strong moisture permeability. In order to prevent external material from getting into the inside of LEDs to cause malfunction of LED, each content of Bromine and Chlorine is required to be less than 225 PPM. The combined content of Bromine and Chlorine in the external glue of the application products is required to be less than 375 PPM.

- ◆ The encapsulated material of the LED is silicone. Therefore the LED has a soft surface on the top of package. The pressure on the top surface will affect the reliability of the LED. Precautions should be taken to avoid the strong pressure on the encapsulated part. So when using the picking up nozzle, the pressure on the silicone resin should be properly applied.
- ◆ Static electricity or surge voltage damages the LED. Damaged LED will show some unusual characteristics, such as lower forward voltage, or even no light emitted. All devices, equipment and machinery must be properly grounded. At the same time, it is recommended that wrist bands or anti-electrostatic gloves, anti-electrostatic containers are used when dealing with the LED.

Storage

- ◆ Before opening the package, the LED should be kept at temperature of 30°C or less and humidity of 60% RH or less, and the LED should be used within a year.
- ◆ After opening the package, the LED should be stored at temperature of 30°C or less and humidity of 10% RH or less, and the LED should be soldered within 24 hours. It is recommended that the LED is best operated at temperature of 30°C or less and humidity of 60% RH or less. For unused LED, it should be stored in moisture proof packages, such as sealed containers with packages of moisture absorbent material (silica gel). It is also recommended to return the LED to the original moisture proof bag and to reseal the moisture proof bag again.

Packaging

A) Package tape specifications: 4000 pieces/reel

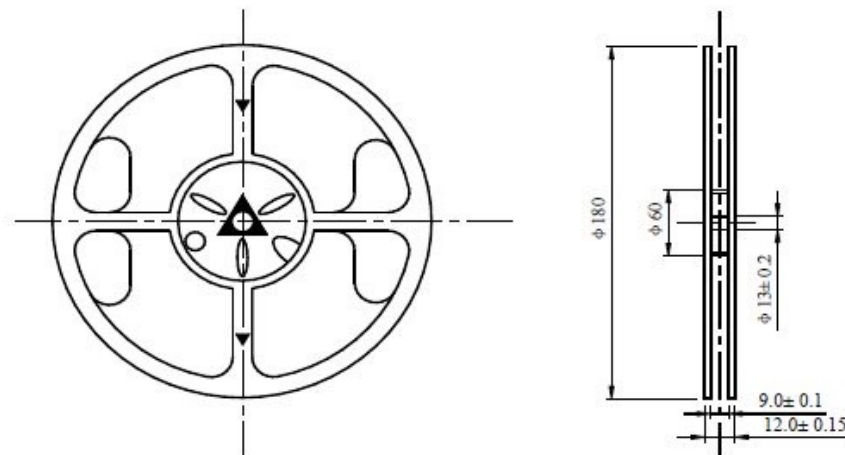

B) Dimensions of tape (Unit in millimetre)

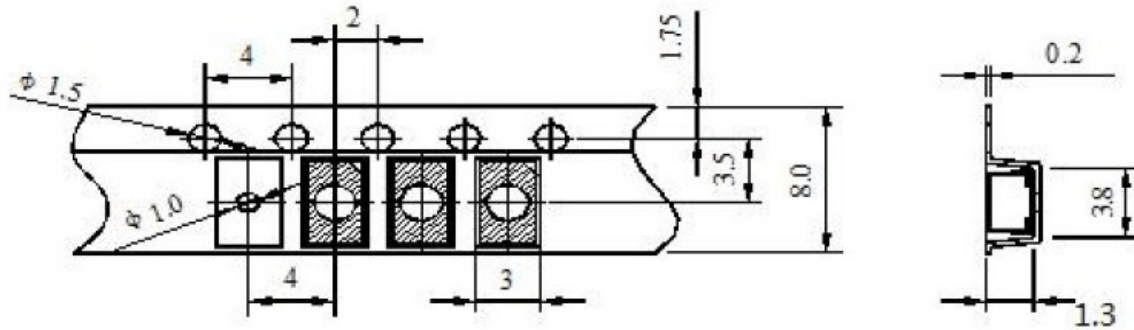

- Notes :
1. Empty component pockets are sealed with top cover tape.
 2. The maximum number of missing LED lamp is two.
 3. The cathode is oriented towards the tape sprocket hole in accordance with data sheet specifications.